

Instruction Manual

Model F100-1

PICTURE FRAMING

STUDIO SAW

LOGAN[®]
GRAPHIC PRODUCTS, INC.
Tools for the Art of Framing
www.logangraphic.com

Description

The Studio Saw Model F100-1 is an economical framing saw which will produce 45° mitres for picture frame corners. Features include : Adjustable angle setting, moulding clamps, and a specially designed saw blade for close tolerance cutting that makes producing your own professional quality picture frames possible.

Optional fence kit (Model F100-4) will allow saw to be upgraded to a professional system.

Producing professional quality picture frames is now easier then ever.



Identification

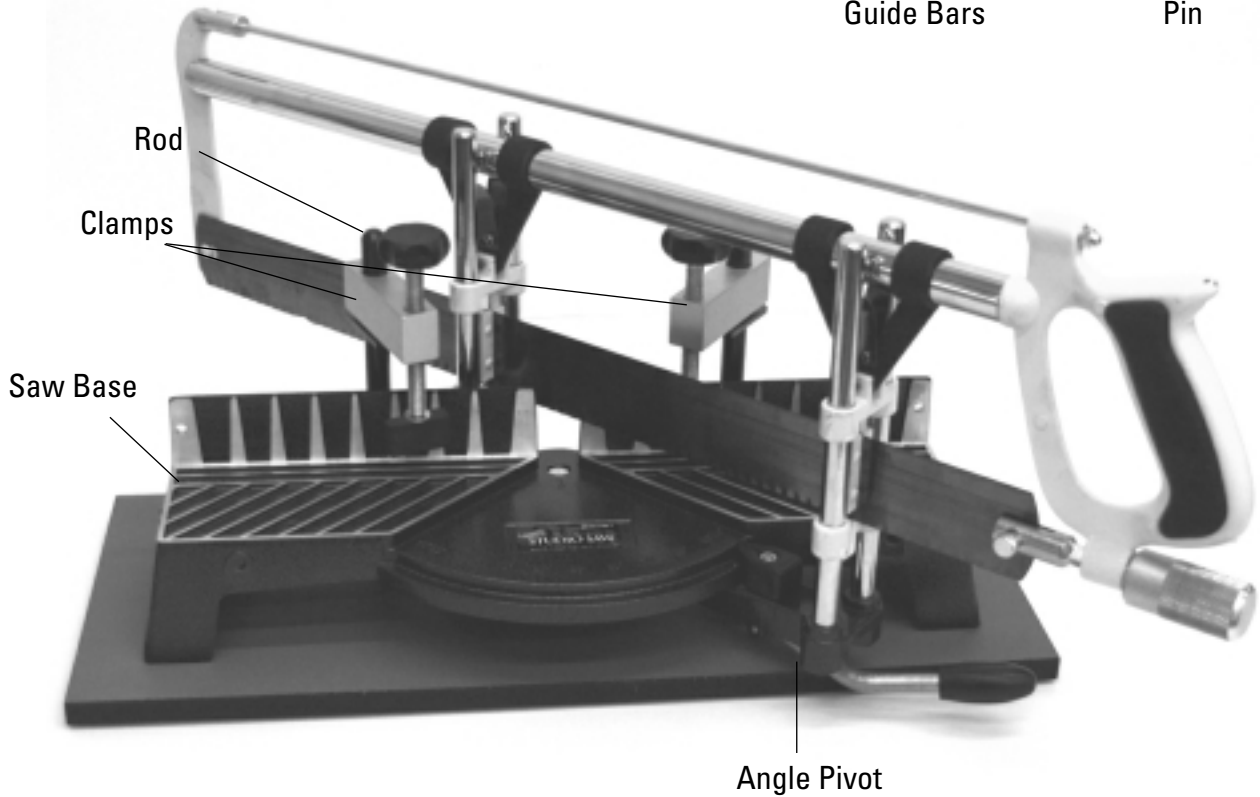
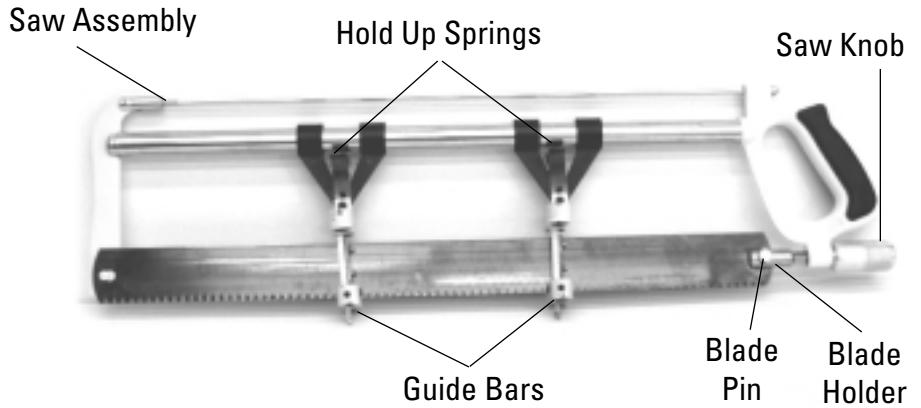
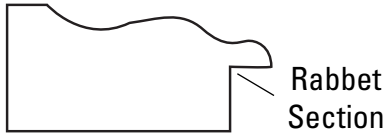

Clamps - Quick slide moulding clamps used to keep moulding secure for cutting.

Angle Pivot - Adjustment arm that holds saw assembly. Rotate to various angle setting from 45° to 90°.

Saw Assembly - 24 tooth/inch saw blade for precise cutting. Knob allows simple blade change. Guide bars keep saw blade from bending so straight cuts are possible.

Rod - Clamp support rod.

Saw Base - Main platform of saw.

Hold Up Springs - Springs which hold up saw so moulding can be maneuvered on fence.

Blade Pin - Holds saw blade.

Saw Knob - Nut to tighten blade tension.

Blade Holder - Holds nut and pin together

Rabet - Undercut of moulding which holds frame material.

Parts List

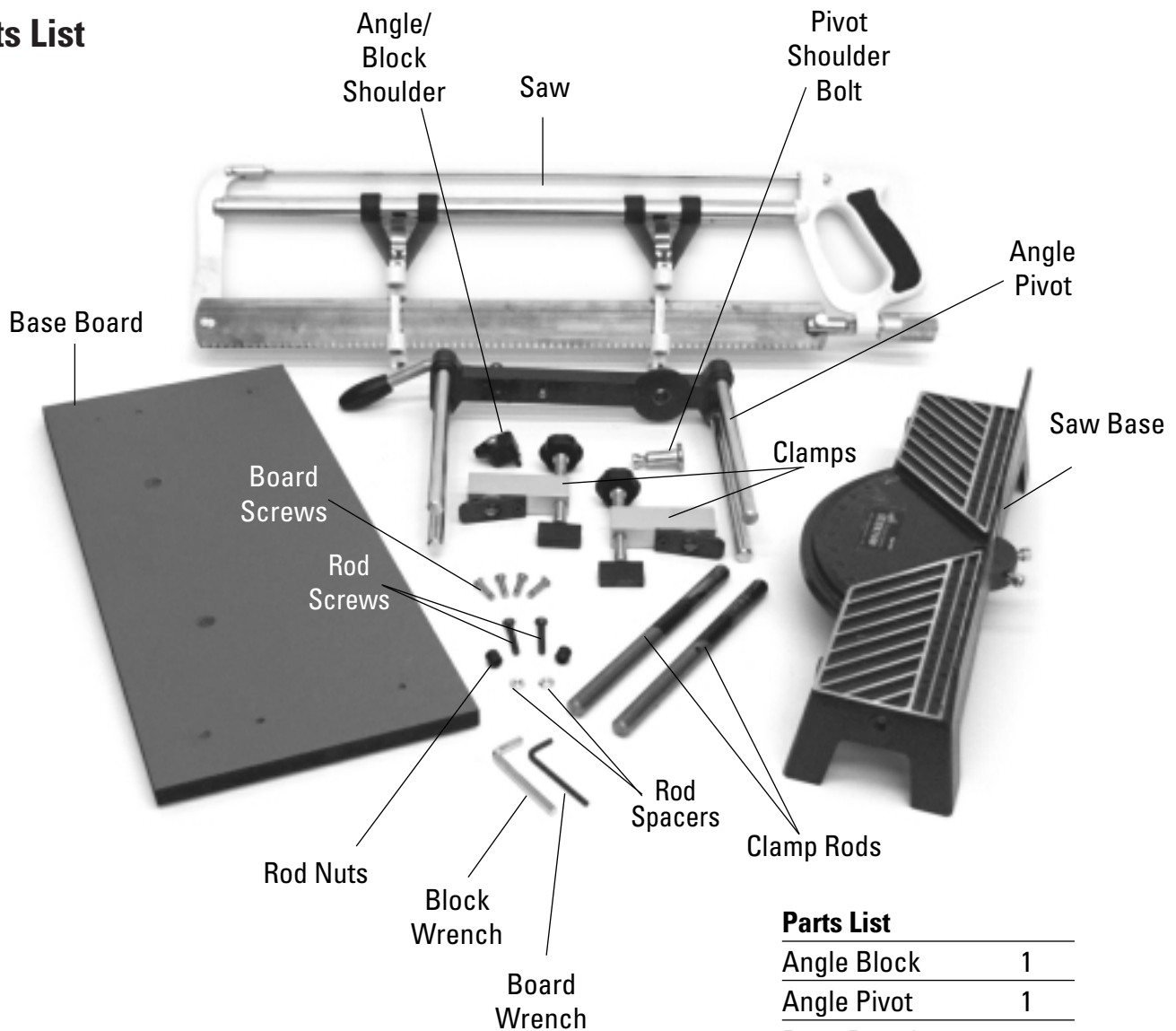

Parts List

Angle Block	1
Angle Pivot	1
Base Board	1
Block Wrench	1
Board Screws	4
Board Wrench & Clamp Wrench	1
Clamp	2
Clamp Rod	2
Pivot Shoulder Bolt	1
Rod Nut	2
Rod Screw	2
Rod Spacer	2
Saw	1
Saw Base	1

Pivot Handle Assembly

1. Insert big pin and spring into hole (Fig. 1).
2. Insert handle tip into pin hole and nub into spring (Fig. 2).
4. Slide small pin thru pivot and handle. Tap in with hammer (Fig. 3).

Fig. 1

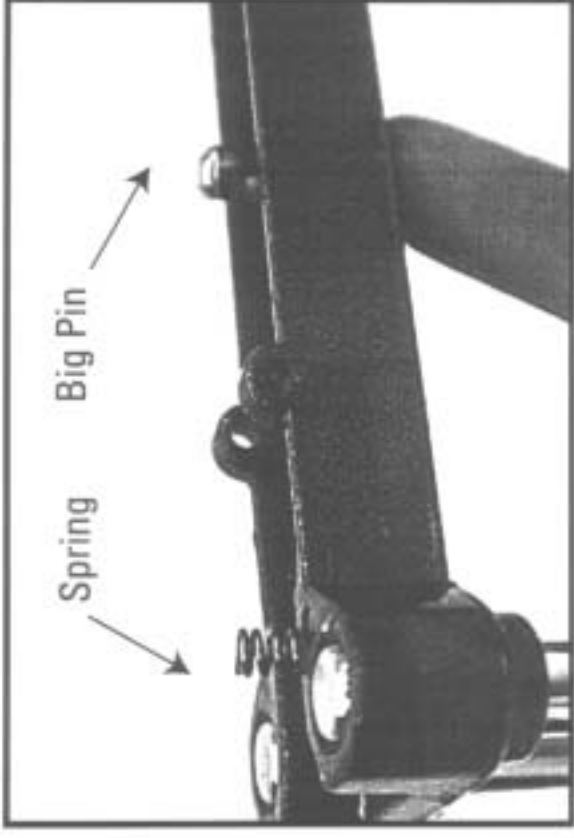
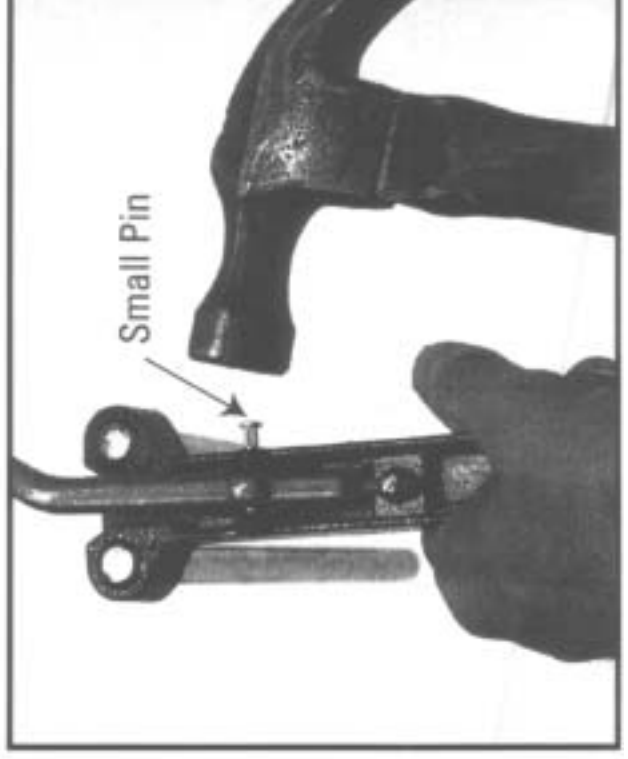

Fig. 2



Fig. 3



Assembly Procedure

A. Angle Pivot

1. Turn base over and align pivot over base.
2. Insert angle pivot bolt thru holes (Fig. 1).
3. Tighten two screws tight (Fig. 2).

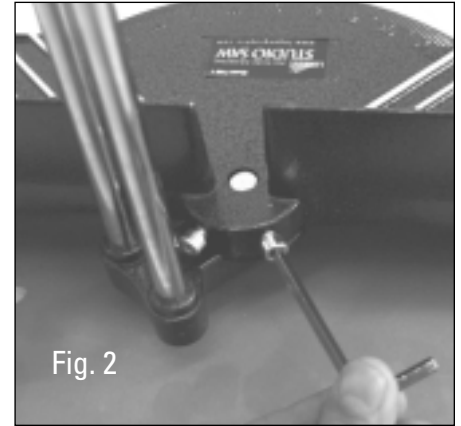
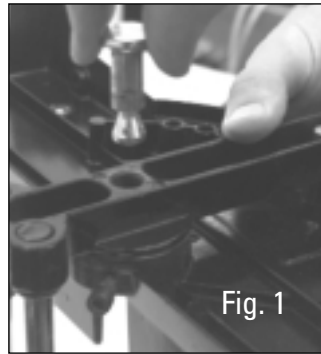

B. Angle Block

1. Align angle block onto pivot (Fig. 3).



- While tightening screw, rotate pivot until pivot drags slightly.

NOTE: Amount of drag on pivot increases accuracy of cut.

C. Base

1. Turn saw base over and install base board. Be sure holes for rods are located toward back of saw base (Fig. 4).

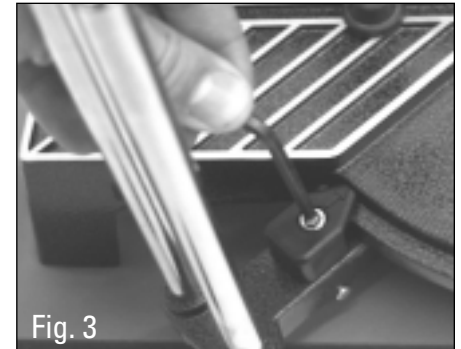

D. Clamp Rod

1. With rounded end facing up, set rods into holes in base board.
2. Align holes in rods with holes back of saw base
3. Install screw thru base, thru spacer and thru rod. Tighten with nut. (Fig. 5).
4. Slide clamps onto rods.

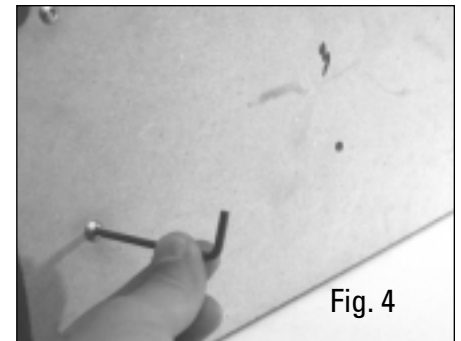

E. Saw

1. Slide saw onto guide rods (Fig. 6).
2. Slide down until hold up springs rest on rod tops.

F. Mounting - Optional



- Mount base board to table using lag bolts supplied. Drill 1/4" (6mm) pilot hole for bolts.



- Use two 4" deep throat C-clamps. Available at local hardware store.

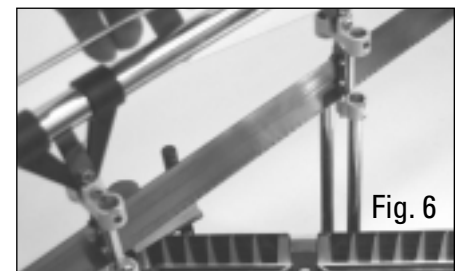
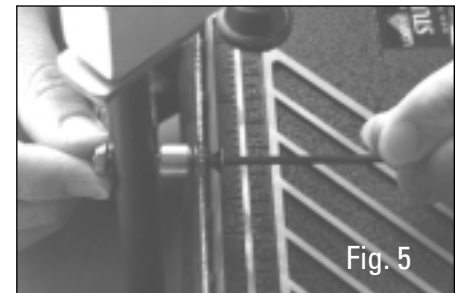

Preparation

A. Calculate Amount of Moulding Needed

1. Inside length and outside length differ because of 45° mitre.

To calculate actual length needed (outside length) use this formula:

$$\text{Outside length} = (\text{inside length}) + (2 \times \text{moulding width}) + (1/8'' \text{ clearance})$$

Clearance: Allows frame material room to fit into frame.

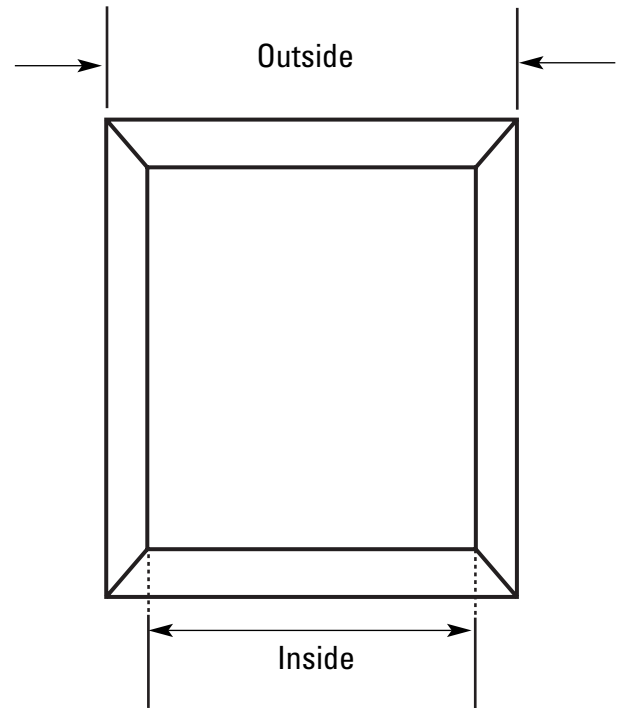
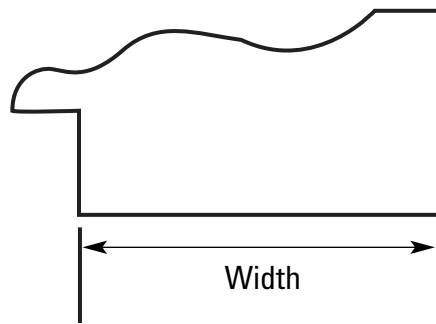

EXAMPLE:

Inside dimensions = 16" x 20"

Moulding width = 1-1/2"

$$\text{Outside Lengths} = 16'' + (2 \times 1\text{-}1/2'') + 1/8'' =$$

$$16'' + 3'' + 1/8'' = 19\text{-}1/8''$$

$$20'' + (2 \times 1\text{-}1/2'') + 1/8'' = 23\text{-}1/8''$$

$$\text{So... } 2 \text{ pieces } \times 19\text{-}1/8'' = 38\text{-}1/4''$$

$$2 \text{ pieces } \times 23\text{-}1/8'' = 46\text{-}1/4''$$

$$\text{TOTAL } 84\text{-}1/2''$$

Needed :

Either 2 pieces 19-1/8" and 2 pieces 23-1/8" or

1 piece 38-1/4" and 1 piece 46-1/4" or

1 piece 84-1/2"

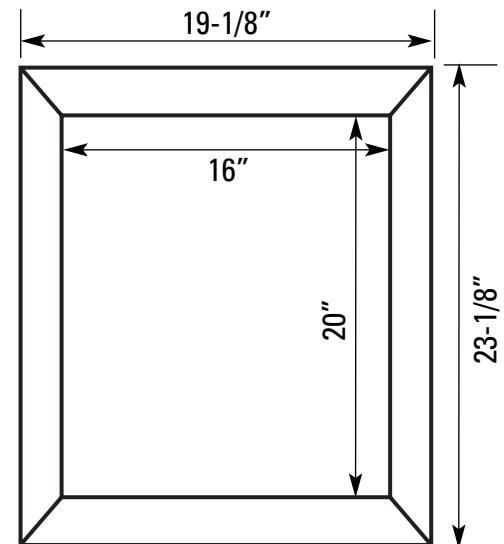

Operation

A. First Cut

1. Set pivot to 45° on right (Fig. 7).
2. Place moulding against fence finished side up and rabbet facing operator.
3. Slide moulding under saw blade far enough so full 45° cut can be made.
4. Adjust clamp feet onto moulding and tighten knobs on both clamps.
5. Cut moulding (Fig. 8)



- By making long full strokes accuracy is improved and cutting is easier.



- Always cut long pieces first. If mistake is made, shorter pieces can be salvaged.

B. Second Cut

1. Set pivot to 45° on left (Fig. 9)
2. Using at tape measure and pencil mark cut dimension on top of moulding (Fig. 10)
3. Slide moulding against fence and lower blade onto right side of mark (Fig. 11).
4. Tighten clamps.
5. Cut moulding (Fig. 12).

NOTE: To increase accuracy, use the completed cut moulding to line up location of saw blade for second cut.

6. Deburr bottom cut edge using sandpaper, sander or file.

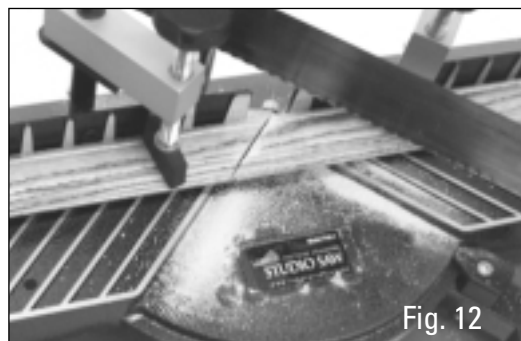
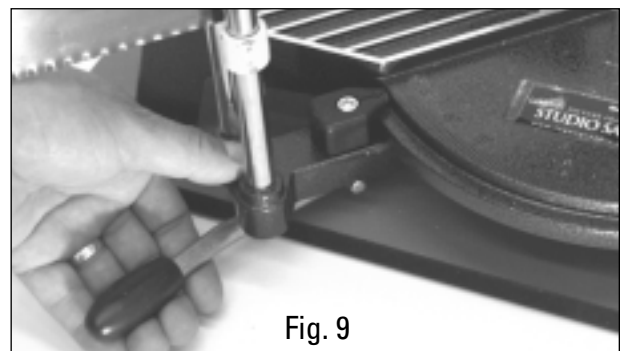
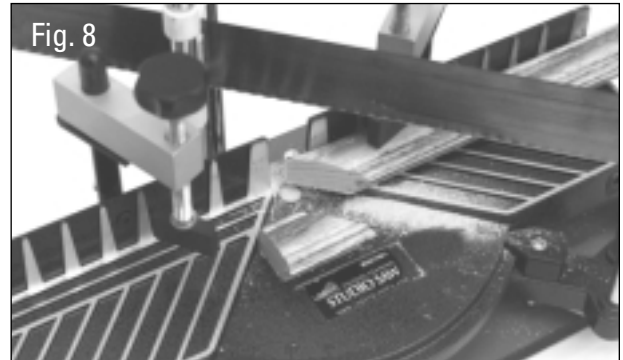
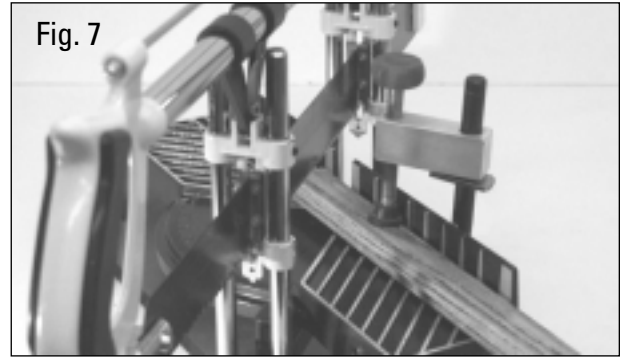

Maintenance

C. Change Blade

1. Loosen and remove knob (Fig. 13).
2. Remove pin (Fig. 14).
3. Remove holder (Fig. 15).
4. Replace blade.
5. **Important - tooth direction on blade must be away from handle.**
6. Reassemble.
7. Tighten knob extra tight.

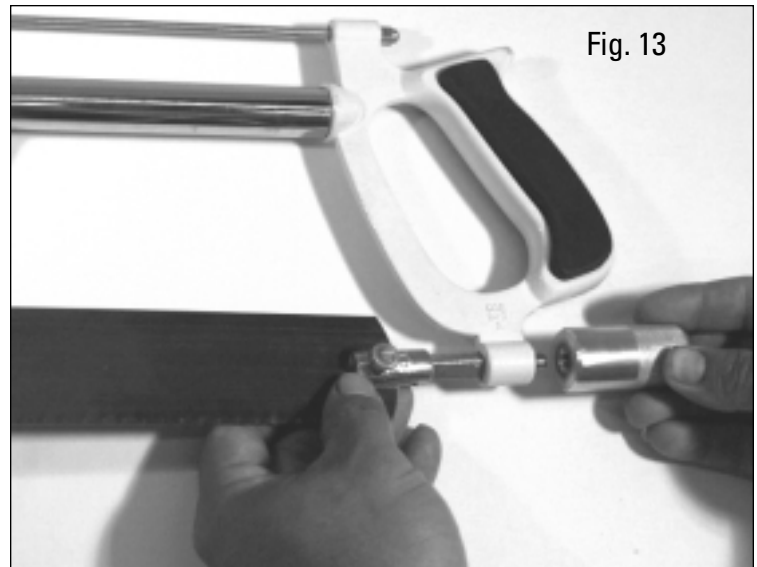

Fig. 13



Fig. 14



Fig. 15

Trouble Shooting

Problem	Solution
Saw does not cut straight.	<p>Increase blade tension using knurled nut under handle.</p> <p>Tighten both swivel screws on back of saw base equally.</p> <p>Tighten down on the angle block pointer, be sure you can still move the saw swivel from left hand 45° to the right hand 45° marks.</p> <p>Make sure the side of moulding that's being clamped is secure.</p>
Difficult or slow cutting.	<p>Make sure the saw blade is correctly installed (teeth facing away from handle).</p> <p>Replace saw blade.</p>
Clamp does not hold moulding securely.	<p>Turn clamp 90° so that it pushes the moulding into the base and back of fence of the saw body.</p> <p>Make sure the clamp posts are tight and secure.</p>
Moulding lengths are not consistent.	<p>Remove any saw dust, debris or splinters from the moulding end or from between the moulding and saw back fence.</p> <p>O.K. to have lengths being cut 1/8th of inch oversize than under size as the lengths can be sanded to match.</p> <p>Make sure clamps and clamp posts are tight.</p>

Warranty

Logan Graphic Products, Inc. ("Logan") warrants the Studio Saw - Model F100-1, to be free from defects in parts and workmanship for a period of one year from the date of original purchase. Logan warrants that it will either repair or replace, at its sole discretion, any necessary replacement parts found to be defective. Should the product need to be returned to Logan for repair or replacement parts, authorization for any return must come from Logan in writing. Costs of returning the product to Logan, including insurances, shall be borne by the purchaser. Logan shall not be liable for any damages or losses, incidental or consequential, direct or indirect, arising from the use of this product. This warranty extends only to the original purchaser and is not assignable or transferable. This warranty is in lieu of all other warranties, expressed or implied.





Logan Graphic Products Inc.,
1100 Brown Street, Wauconda, IL 60084
Toll Free 1 800 331 6232
www.logangraphic.com

Reference Part No. L805-N