

Model 201

# Oval & Circle

MAT CUTTER

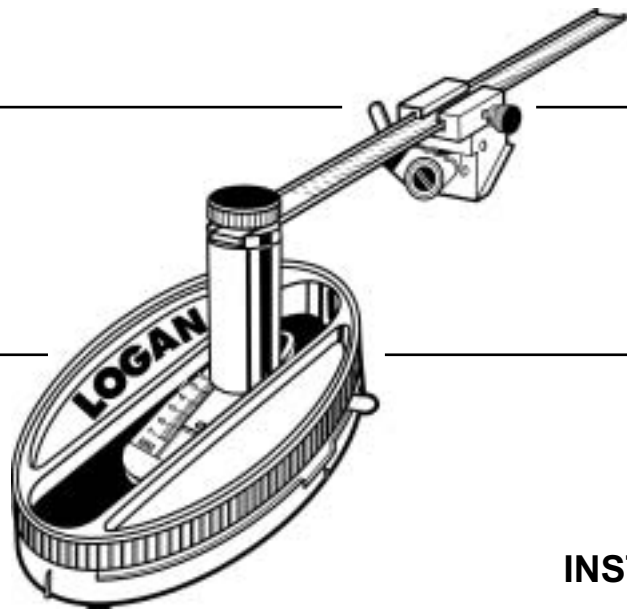

[www.logangraphic.com](http://www.logangraphic.com)

INSTRUCTION AND OPERATION MANUAL

# Table of Contents:

1	Identification of Machine Parts
2	Blade Installation
3	Settings
4-5	Marking and Positioning
6-7	Cutting
8	Creative
9	Troubleshooting
10-11	Parts List
12	Logan Products

## ***Warranty Information***

Logan Graphic Products, Inc. ("Logan") warrants the #201 3-Step Oval & Circle mat cutter to be free from defects in parts and workmanship for a period of one year from the date of original purchase. Logan warrants that it will either repair or replace, in its sole discretion, any necessary replacement parts found to be defective. Should the product need to be returned to Logan for repair or replacement parts, authorization for any return must come from Logan in writing. Costs of returning the product to Logan, including insurances, shall be borne by the purchaser. Logan shall not be liable for any damages or losses, incidental or consequential, direct or indirect, arising from the use of this product. This warranty extends only to the original purchaser and is not assignable or transferable. This warranty is in lieu of all other warranties, expressed or implied.



# Identification of Machine Parts

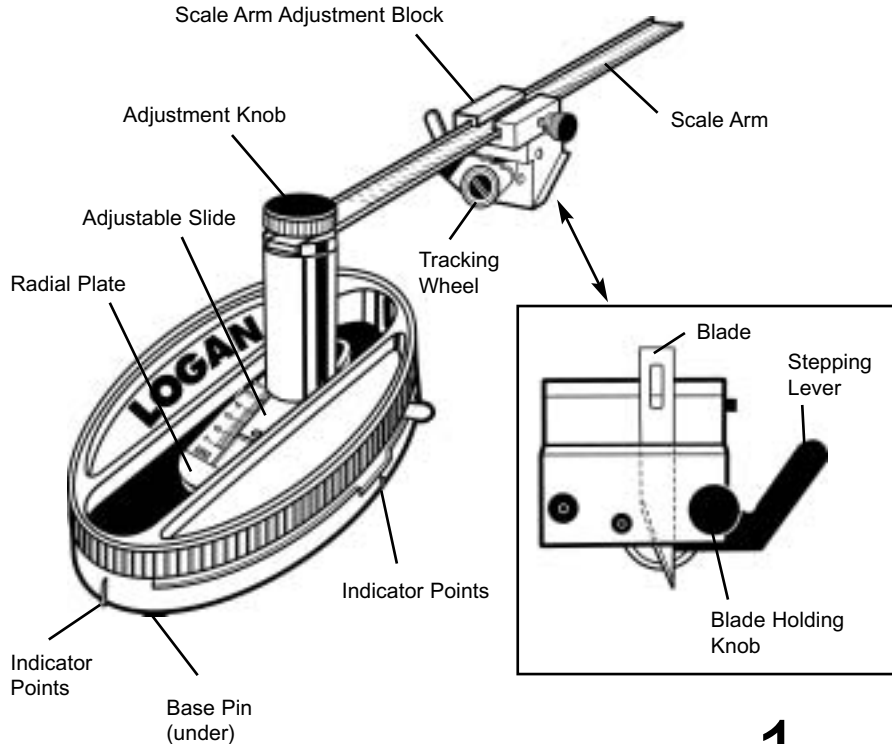

**Scale Arm** Rotating arm with 20" scale for setting the width of the oval.

**Scale arm adjustment block** Block which can be moved over the scale arm for setting the width of the oval to be cut.

**Tracking wheel** Wheel that rolls on the cutting head allowing it to naturally track the shape of an oval or circle.

**Adjustment knob** Knob which when loosened allows adjustable slide to be adjusted and when tightened, locks the slide in place.

**Adjustable slide** Plate which can be adjusted on the radial plate scale to set the difference between the width and the height of the oval.

**Radial Plate** Rotating center cam of the oval assembly.

**Indicator points** Points on each side of the oval base used to align the oval base on pre-drawn lines.

**Base pins** Small spikes in the bottom of the oval base used to help anchor the oval base while cutting.

**Stepping lever** Adjustable lever with three steps used to gradually increase blade depth after each cutting revolution.

**Blade holding knob** Knob which when tightened holds the blade in place inside the cutting head.

# Installing a Blade Fig 1

1. Loosen the blade holding knob 2 or 3 turns.
2. Insert blade from the top down into blade holder slot. NOTE: Blade tip direction.
3. Pushing down on the blade end with thumb, wiggle blade tip into proper setting.
4. Tighten blade holding knob.



***Helpful Hint***

- *Blade sharpness varies. When the cut is rough, change the blade.*

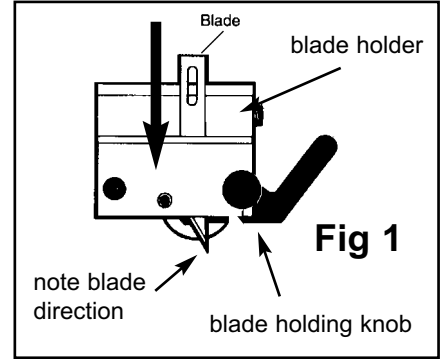

# Setting the Scales

EXAMPLE: Mat with 5" x 7" opening or mat with 6" circle.

## Setting the Width Scale Fig 2

1. Set the scale arm adjustment block to desired width.

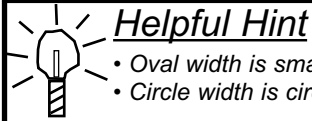

### Helpful Hint

- Oval width is smallest number in opening size. (5" is less than 7" so set to 5")
- Circle width is circle opening (6")

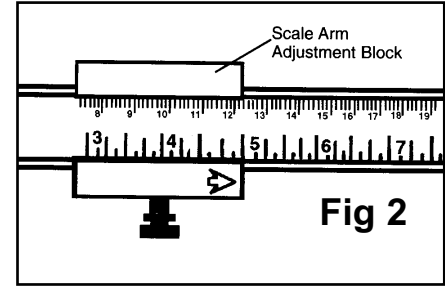
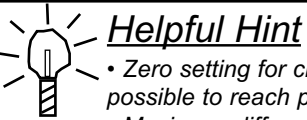

Fig 2

## Setting the Difference Scale Fig 3

1. Calculate oval difference by subtracting width from height.  
(7" - 5" = 2" for oval or 6" - 6" = 0" for circle)
2. Rotate scale arm until radial plate scale appears in the opening.
3. Loosen adjustment knob on oval post.
4. Holding cutter base, slide scale arm to adjust notches on radial plate scale.
5. Tighten adjustment knob.



### Helpful Hint

- Zero setting for circle is directly under oval post. Slide scale arm as far as possible to reach proper setting.
- Maximum difference is 3" on this cutter.

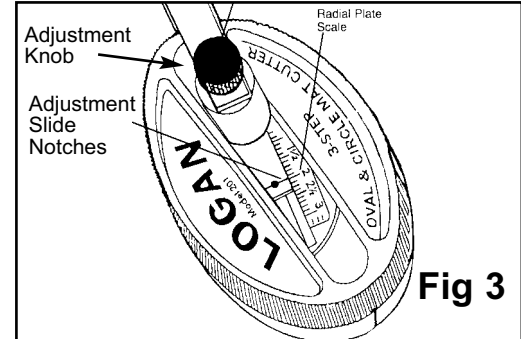
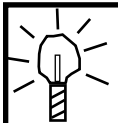

Fig 3

# Marking the Mat Fig 4

1. On the color side of the matboard draw cross hairs in the center of opening location 4" to 6" long.



## Helpful Hint

- Draw the lines lightly so they can be erased.
- Locate center point of mat by drawing lines from corner to corner. Use a T-Square to draw cross hairs.

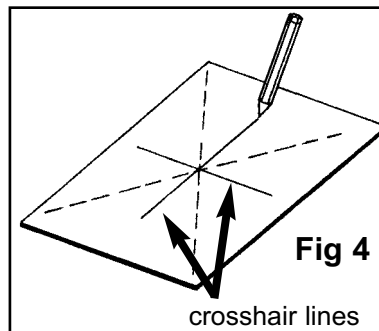

# Positioning the Cutter

1. Press the stepping lever down to it's lowest setting. (safety) (Fig 5)
2. Put the backing sheet under the matboard to be cut. (Fig 6)

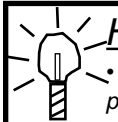

## Helpful Hint

- The backing sheet should be bigger than the cutting sheet and is used to prevent the blade from cutting into your table top.
- Always use a backing sheet.

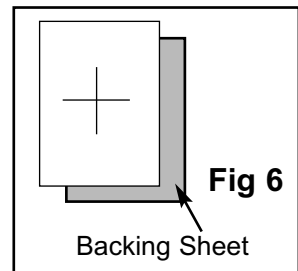
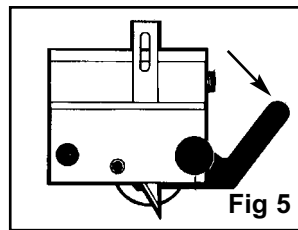

3. Align the indicator points on base with crossed lines drawn on mat.  
Push down base so pins sink into matboard. (Fig 7)

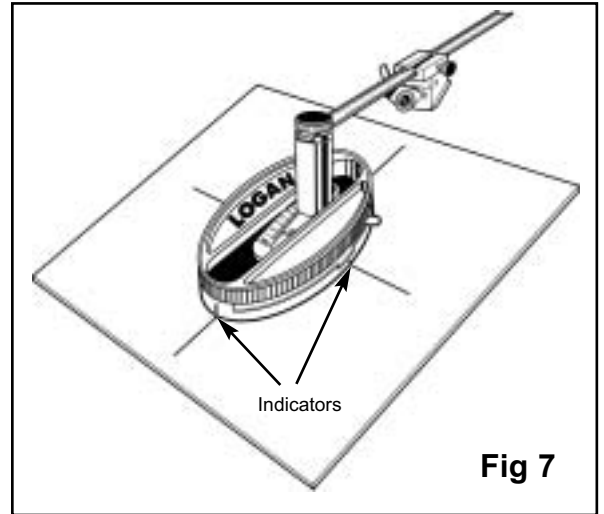

# Cutting The Mat



## Helpful Hint

- Standing while cutting is the easiest method.
- The cutting process consists of 4 rotations, the first rotation produces a track and the next will slowly lower the blade through the mat.

1. Rotate the scale arm to one o'clock position. (Fig 8)
2. With your left hand on the oval base place your right hand on the scale arm.
- 3 Grip the scale arm with your thumb on top of the sliding block but with fingers away from swivel head. (Fig 9)
4. Rotate scale arm to five o'clock position. (Fig 10)



## Helpful Hint

- Downward pressure is required on the scale arm. However do not over exert as this may cause the stepping lever to skip position.
- Be careful that your fingers do not interfere with the swivel cutting head while cutting.

5. Remove your right hand from the scale arm and keeping your left hand on the base, twist the base and mat board counterclockwise until the scale arm is back to a one o'clock position.
6. Rotate scale arm to five o'clock position again to complete revolution.

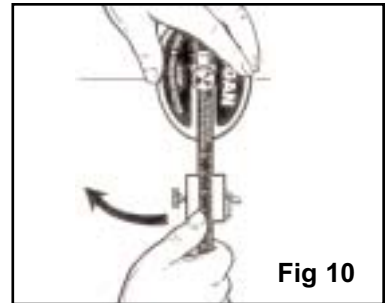
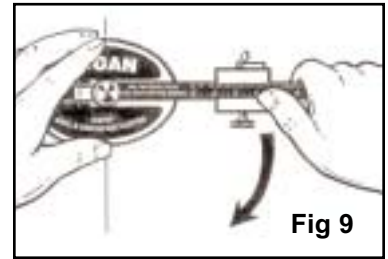
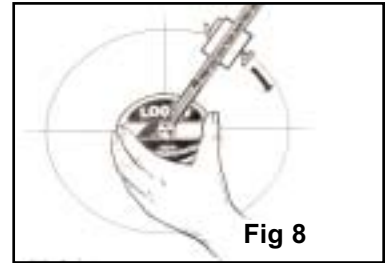



7. Using your index finger, lift the stepping lever upwards one step or click (Fig 11). This sets the blade into it's first cutting position.

8. Repeat steps 3 through 6.

9. Lift stepping lever upwards one step to next setting and repeat cutting. (2nd step)

10. Lift stepping lever upwards all the way to the last setting and repeat cutting. (3rd step)

11. Click stepping lever down and then remove cutting base to reveal finished mat.

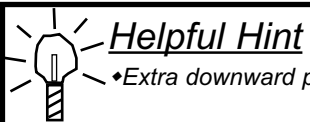
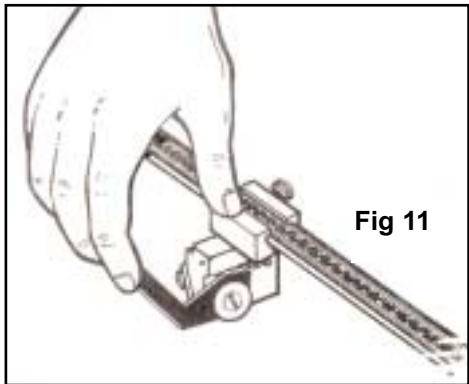

### Helpful Hint

♦Extra downward pressure on the scale arm on the last cut helps the blade cut through.

# Creative Matting

## 1. Cutting a double Oval

EXAMPLE: 11X14 DOUBLE OVAL WITH  
7 1/2X 9 1/2 OPENING

1. Start with two pieces of even sized matboard. Using either glue or double sided tape adhere both pieces of mat together as shown. Only put the glue or tape around the outside edges and none in the middle.
2. Measure and cut a oval in the top mat to a size of 8" x 10". Set the dropout aside and locate the four pin marks on the mat below.
3. Insert a backing sheet underneath the mat you are cutting.
4. Set the oval cutter to a 7 1/2" x 9 1/2" and line the base pins in the pin marks on the back mat. Cut the second oval as usual. This should produce a perfectly aligned 11 x 14 double mat with a 7 1/2" x 9 1/2" opening.

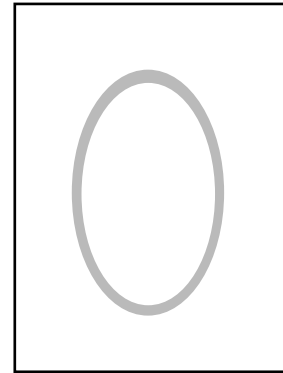
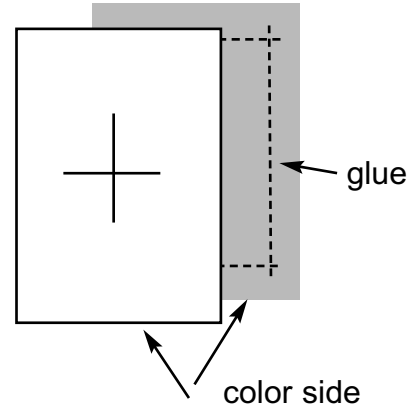

# Trouble Shooting

## **The blade is difficult to insert into the blade holder.**

Make sure that the blade holding screw is loosened. Make sure that the blade goes in far enough into the blade holder so that the tip of the blade is protruding from the bottom. If the blade will not enter the blade holder use the blade of a small screwdriver to gently release the loosened blade cover plate so the blade can be inserted.

## **The cut is not aligning with itself as it goes around.**

See that your fingers are away from the cutting head while gripping the scale arm so as not to interfere with the free swivel movement of the cutting head.

## **The blade tip is breaking.**

Make sure you are using a proper backing sheet so the blade does not cut into the table top causing the tip of the blade to break. Change your blade, a dull blade may allow the tip to break off.

## **The blade is not cutting all the way through the mat.**

Make sure that sufficient pressure is be applied on the scale arm on the last cutting step to see that the blade cuts all the way through the mat.

## **The stepping lever skips it's position**

See that you are not applying too much pressure on the scale arm during the first few steps causing the stepping lever to jump into the next position.

# Parts Schematic

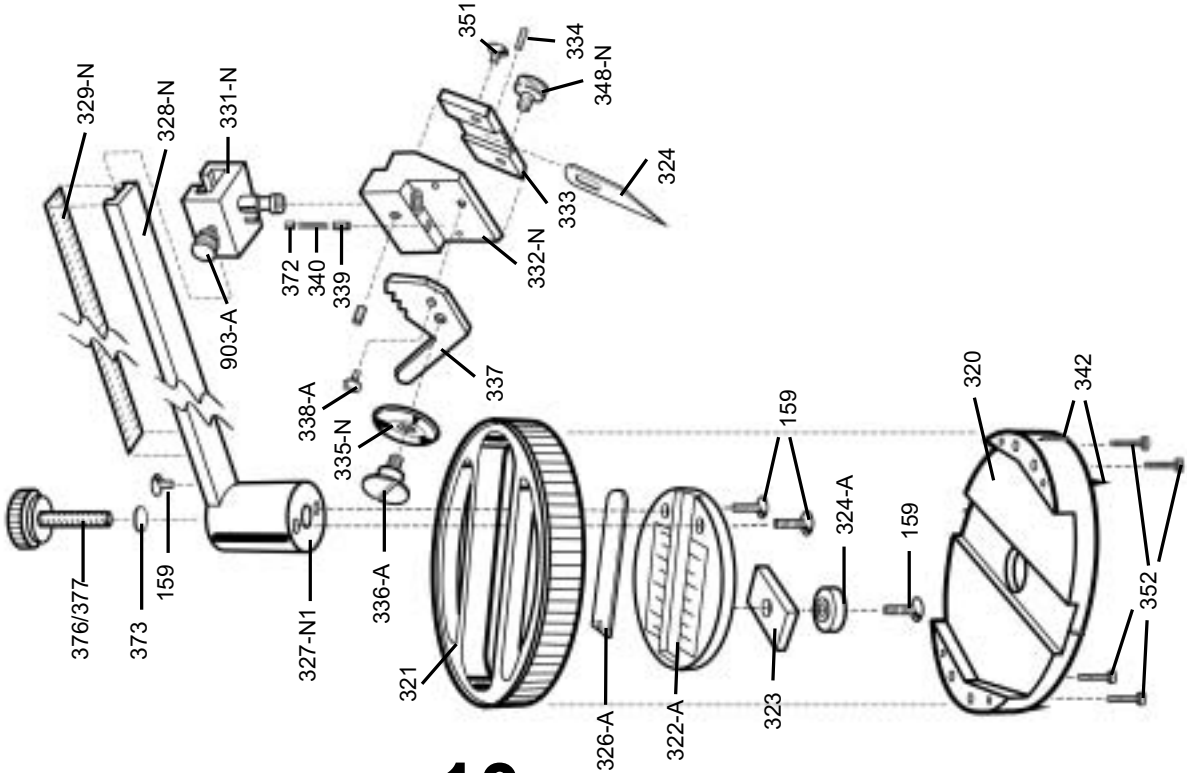

<u>Part#</u>	<u>Description</u>
159	flat head screw
320	oval base, bottom
321	oval base, top
322-A	radial plate
323	sliding block
324	blade
324-A	adjustment nut
326-A	adjustable slide
327-N1	ovalpost
328-N	radius arm
329-N	scale
331-N	channel block
332-N	swivel foot
333	cover plate
334	tip setting screw

<u>Part#</u>	<u>Description</u>
335-N	roller wheel
336-A	pivot pin body
336-B	pivot pin (not shown)
337-N	stepping lever
339	pressure pin
340	tension spring
342-N	holding pins x 4
373	plug
348-N	blade holding knob
351	blade cover screw
352	base screw
372	step tension adjustment screw
376/377	adjustment knob
903-A	channel block screw

For technical service or replacement parts  
call 1-800-331-6232

# Logan Mat Cutters

Model#	Description
301-S	<b>Compact</b> 32" base board with guide rail, mat guide, bevel cutting head and straight cutting head.
450	<b>Intermediate+</b> 40" base board with guide rail, mat guide, squaring bar, bevel cutting head, straight cutting head and production stop.
750	<b>SimplexPlus</b> 40" base board with guide rail, mat guide in aluminum channels 27" squaring arm, two guide rail stops, laminate surface cutting board, bevel cutting head and straight cutting head.
650	<b>Framer's Edge</b> 40" base board with dual purpose straight and bevel cutting head, 27" and 9" squaring arms, laminated top, mat guide and production stops.

#301-S

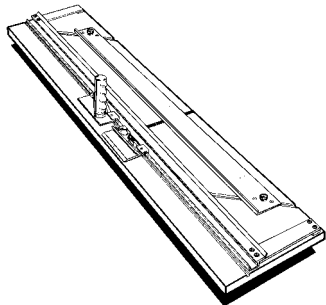

#450

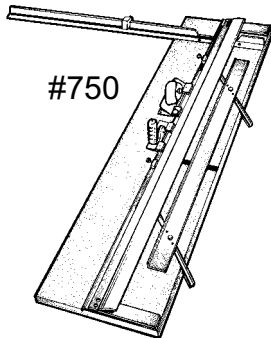
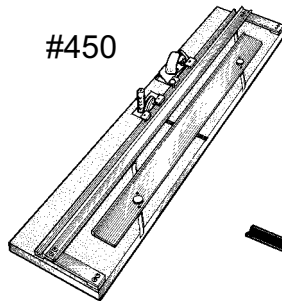

#750

#650

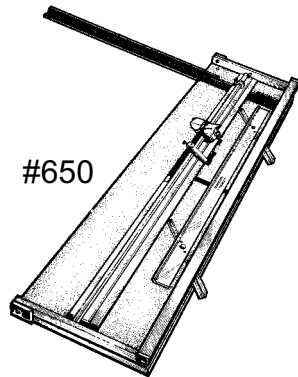

See us at [www.logangraphic.com](http://www.logangraphic.com)  
E-MAIL [cs@logangraphic.com](mailto:cs@logangraphic.com)

**Logan Graphic Products, Inc.**  
1100 Brown Street  
Wauconda, IL 60084  
847/526-5515 fax 847-526-5155  
toll free 800/331-6232

L353-N